

GENSET CONTROL MODULE A121H / A241H

Features:

- Models for both 12V and 24V systems.
- One model for both spark ignition and diesel engines.
- 4-alarm light outputs with lamp-test provisions.
- Overspeed adjustment not required. (Overspeed trip point pre-programmed in firmware.)
- User selectable starting mode: full cycle cranking, or single-cycle crank limiter.
- User selectable time delays for engine start and engine stop (cool down).
- Loss of speed signal protection for crank motor circuit.
- Special logic to re-establish cranking following a false start.
- Special logic permits re-starting of hot engine.

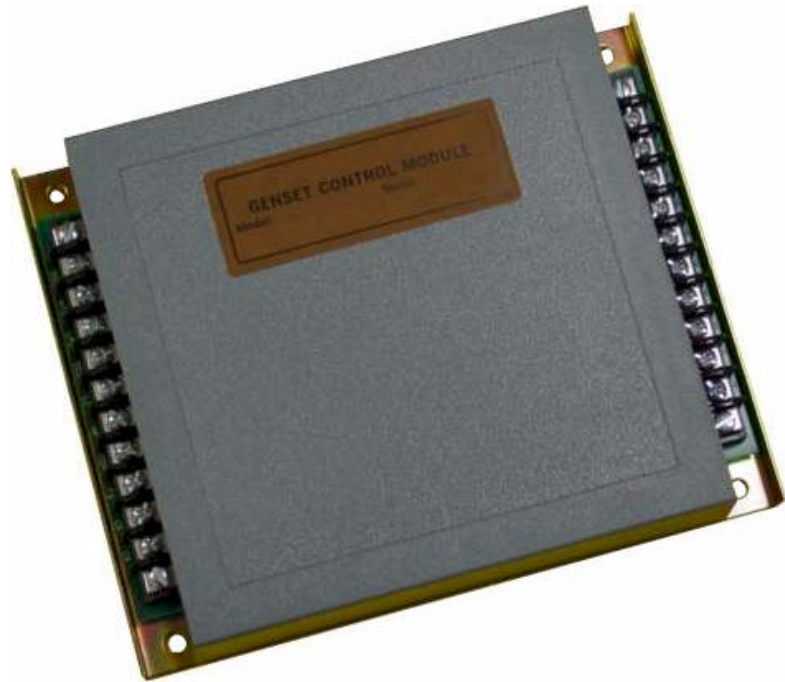

General Description:

The Genset Control Module is a microprocessor based control system which provides complete automatic control of standby generator set engines. Fuel solenoid and/or ignition control, cranking control, and audible alarm control are via heavy duty industrial type relay contacts. Engine temperature and oil pressure monitoring are obtained from engine mounted sensor contacts. Non-adjustable overspeed shutdown and crank termination control are provided internally via a frequency monitoring input terminal. This input signal is obtained from a magnetic pick-up frequency detector which is mounted over the engine ring gear. The Genset Control Module is matched to the number of ring teeth to provide the proper overspeed protection and crank termination control.

A121H / A241H Specifications

Input Voltage: Model A121H: 12VDC nominal, 16VDC max; transient and reverse polarity protected. (Typical: Pickup at 10VDC, Dropout at 6VDC.)

Model A241H: 24VDC nominal, 32VDC max; transient and reverse polarity protected. (Typical: Pickup at 14VDC, Dropout at 9VDC.)

Supply Current: 0.4A maximum plus alarm light burden.

Relay Load Contacts: FS & CS: 10A at 28VDC, inductive; AR: 2A at 28VDC, resistive.

Alarm Light Load: 150mA maximum each output (incandescent inrush is permitted.)

Shutdown Input Contacts: 2 (See operating instructions for start-up override times.)

Frequency Input: 80V RMS maximum, 3V RMS minimum.

Non-adjustable overspeed is "graduated" from 70Hz (6-sec. delay) to 84Hz (instantaneous).

Consult factory for model number suffix vs. number of ring gear teeth.

Crank Disconnect Speed: Internally fixed at 540RPM.

Crank Control: Single-cycle crank limiter: continuous 48 sec. crank period (non-adjustable.)

Cycle cranking: 5 cycles of 12 sec. crank and 12 sec. rest (non-adjustable.)

Time Delays (optional): Delay on start from remote signal: 3 seconds (non-adjustable.)

Delay on shutdown from remote signal: 3 minutes (non-adjustable.)

Shielding: Internal EMI shielding provided.

Ambient Temperature: -25° F to +140° F

Finish: PC Board: Protected with moisture/fungus proof varnish.

Chassis: Zinc plated / yellow dichromate.

Cover: ABS plastic.

Terminal Blocks: Industrial screw-terminal type.

Note 1: Other models available for other frequencies and/or voltages.

Consult factory with your specific requirements.

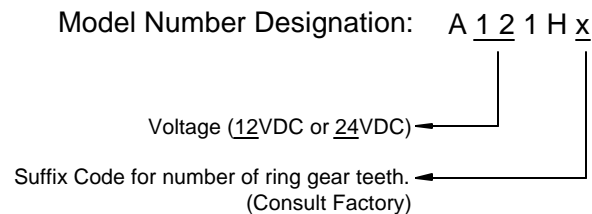

Bouchette Electronics, Inc.

N11325 County Highway Y, Clintonville, WI 54929
(715) 823-7770 (715) 823-7771 Fax www.bouchette.com

A121H / A241H Dimensions

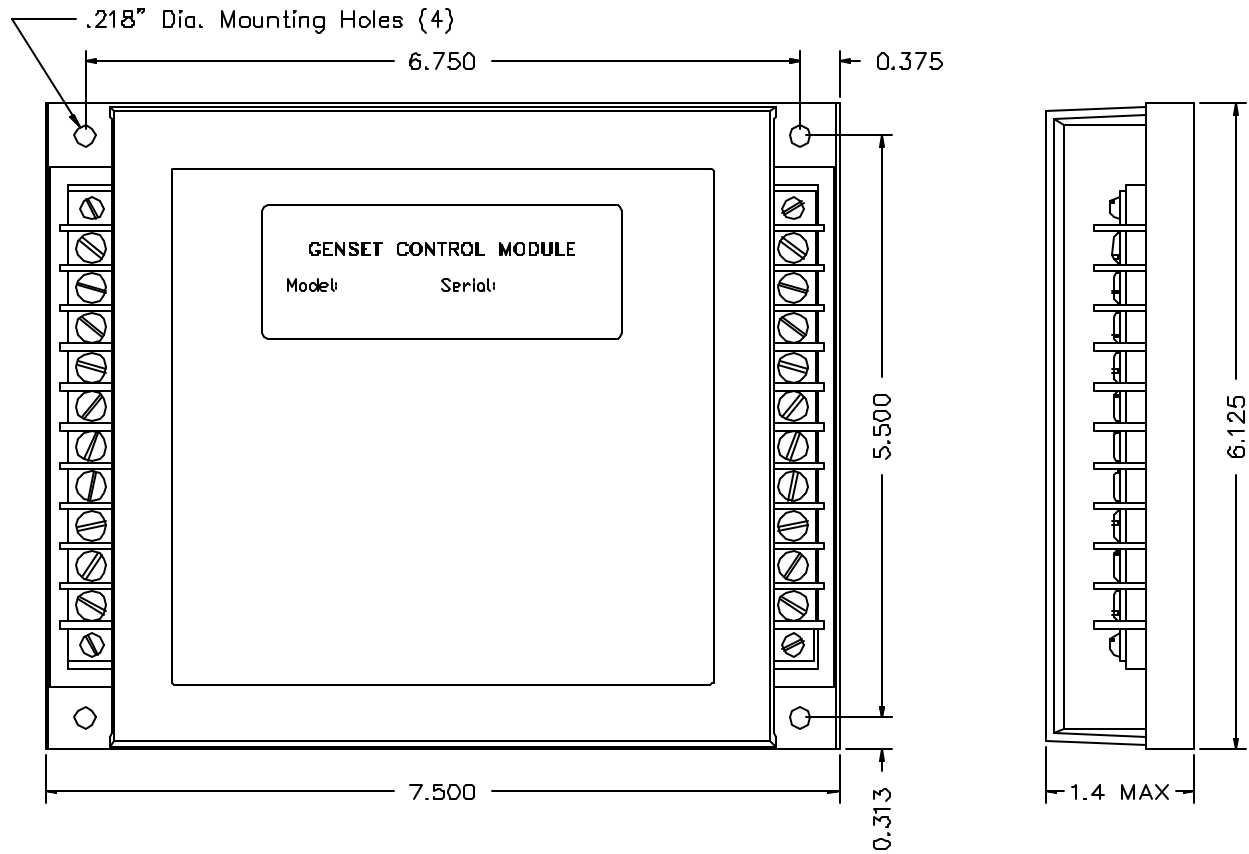

Bouchette Electronics, Inc.

N11325 County Highway Y, Clintonville, WI 54929
(715) 823-7770 (715) 823-7771 Fax www.bouchette.com

GENSET CONTROL MODULE — LEVEL 1

A121H / A241H

Control Switch Inputs

The following operator panel controls are wired into the microprocessor through the front-mounted terminal blocks:

1. Run/Stop/Auto Switch.

a. “Run” position causes the engine to start and run immediately.

b. “Auto” position allows the unit to be controlled via any remote single-pole dry-type contact (transfer switch, remote start switch, etc.). Contact closure causes the unit to start and run, while contact opening causes the unit to shut down. *Also see Time Delay Select for time delay options.*

c. “Stop” position de-energizes the control module for immediate shutdown.

2. Lamp Test Push-Button.

Energizes all alarm lights simultaneously. This feature is disabled with the Run/Stop/Auto selector switch in the “Stop” position, and has no other effect on unit operation.

Relay Functions

1. Master Control Relay (FS).

Operates the fuel solenoid, etc.

2. Cranking Control Relay (CS).

Controls engine cranking functions.

3. Alarm Relay (AR).

Provides contact (2-amp. maximum) for remote alarm indication, bell, etc. The alarm relay is energized for all engine fault conditions.

Safety Shutdown Inputs

1. Low Oil Pressure (LOP) Shutdown.

Monitoring of oil pressure begins 12-seconds after the unit starts and remains in effect until the unit is shut down (*except as noted in section Microprocessor Program Notes.*) Except as noted, closure of this contact while engine is running results in an engine fault shutdown and alarm with light indication. The LOP signal is derived from an oil pressure sensor switch mounted on the engine.

2. High Water Temperature (HWT) Shutdown.

The engine coolant temperature sensor monitoring begins immediately with the start signal. However, if the water temperature is excessive prior to start, (i.e., heat soak after shutdown), the unit is permitted to start and the high temperature condition is permitted to exist for up to 60-seconds after the unit is running, before an engine fault shutdown and alarm with light indication occurs. If the high temperature condition is corrected within that time period, the microprocessor circuit reverts to normal monitoring. Except as noted, closure of this contact while engine is running results in an engine fault shutdown and alarm with light indication. The HWT signal is derived from a temperature sensor switch mounted on the engine.

3. Overspeed (OS) Shutdown.

Overspeed shutdown protection is provided by a frequency sensing network within the control module. The trip point of the frequency network is fixed at the factory to provide a “graduated” overspeed shutdown beginning at 70Hz with a 6-second shutdown delay, and ending at 84Hz with an instantaneous shutdown. Except as noted, exceeding this speed will result in an engine fault shutdown and alarm with light indication. The control module model is matched to the number of teeth on the engine ring gear.

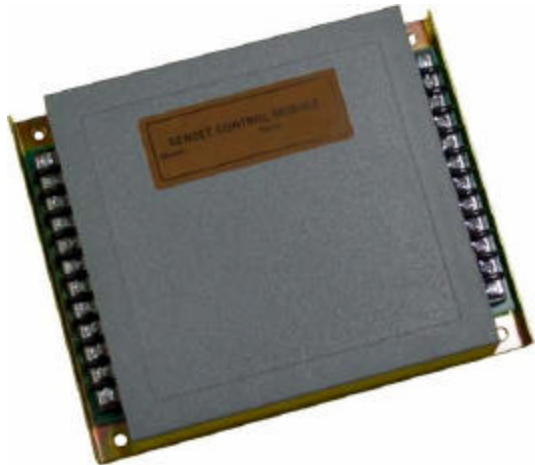

Cranking Control

1. Overcrank (OC) Protection.

Two different cranking cycles are programmed into the control modules microprocessor:

a. Single-Cycle Cranking Feature.

This feature provides a single, non-adjustable, crank period of 48-seconds. Failure of the engine to start within that time results in an “overcrank” engine fault shutdown and alarm with light indication.

b. Cycle Cranking Feature.

The control module may be field-converted to the “cycle cranking” feature by grounding the “CCI” terminal on the control. This feature provide a series of five cranking cycles; each containing a 12-second crank period with a 12-second rest period. Failure of the engine to start by the end of the fifth crank period results in an “overcrank” engine fault shutdown and alarm with light indication.

2. Cranking Disconnect.

The cranking termination speed is obtained from the frequency network within the control module. The microprocessor automatically sets the cranking termination speed at 540 RPM.

3. Loss of Frequency Signal.

The microprocessor will detect an absence of frequency signal while cranking. After the first 12-seconds of cranking, the “overcrank” light begins a staggered flashing pattern to indicate there is no frequency signal input.

If the cycle cranking feature (*1.b above*) was selected; the microprocessor automatically converts to the single-cycle cranking feature (*1.a above*). This conversion prevents the starter motor from re-engaging during the second crank cycle in the event the engine is already running. *Also see section Microprocessor Program Notes.*

Time Delay Select

Combination Delay-On-Start and Cool-Down timing feature: The control module may be field-converted to include this feature by grounding the “TDI” terminal on the control. This feature will delay the start-up of the engine for 3-seconds after the Remote Run contact is closed, and it will delay the shutdown of the engine for 3-minutes after the Remote Run contact is opened. This timing feature can be made active only in the “Auto” switch position, and still permits instantaneous manual starting in the “Run” switch position. Placing the selector switch in the “Stop” position provides instantaneous shutdown of the engine under all conditions. The start delay is intended to prevent unnecessary start-ups from momentary remote run signals, and the stop delay is intended to provide a cool-off running period for the engine after load removal.

Operating Instructions

Microprocessor Program Notes

Internal protection against loss of frequency input signal is programmed in after the unit has started normally. In the event the frequency goes to zero (engine runs out of fuel, frequency signal source fails, etc.), the LOP shutdown circuit is bypassed and a 12-second wait period is initiated. If the frequency returns within this time period, LOP monitoring resumes and operation continues normally. If frequency has not returned at the end of this time period, the engine oil pressure status is observed to determine whether the engine is actually running or stopped. If the engine has stopped, the cranking cycle will begin in an effort to re-start the engine. If the engine has not stopped (loss of input signal, etc.), the unit is shut down with an “overcrank” engine fault and alarm with light indication.



Caution: “Overcrank” indication can mean a loss of frequency input signal during the previous run period. Attempting to re-start the engine without any frequency input signal can destroy the starter motor, which can cause serious personal injury. The frequency signal source is a key component in this system and must be checked out thoroughly whenever an “overcrank” shutdown occurs, since the control module only provides an indication of loss of signal during startup.

Resetting A Fault Shutdown

A shutdown with alarm, due to any fault condition, will prevent any subsequent operation of the generator set. The Run/Stop/Auto selector switch on the operator control panel must be momentarily placed in the “Stop” position to reset these functions.

Bouchette Electronics, Inc.

N11325 County Highway Y, Clintonville, WI 54929
(715) 823-7770 (715) 823-7771 Fax www.bouchette.com

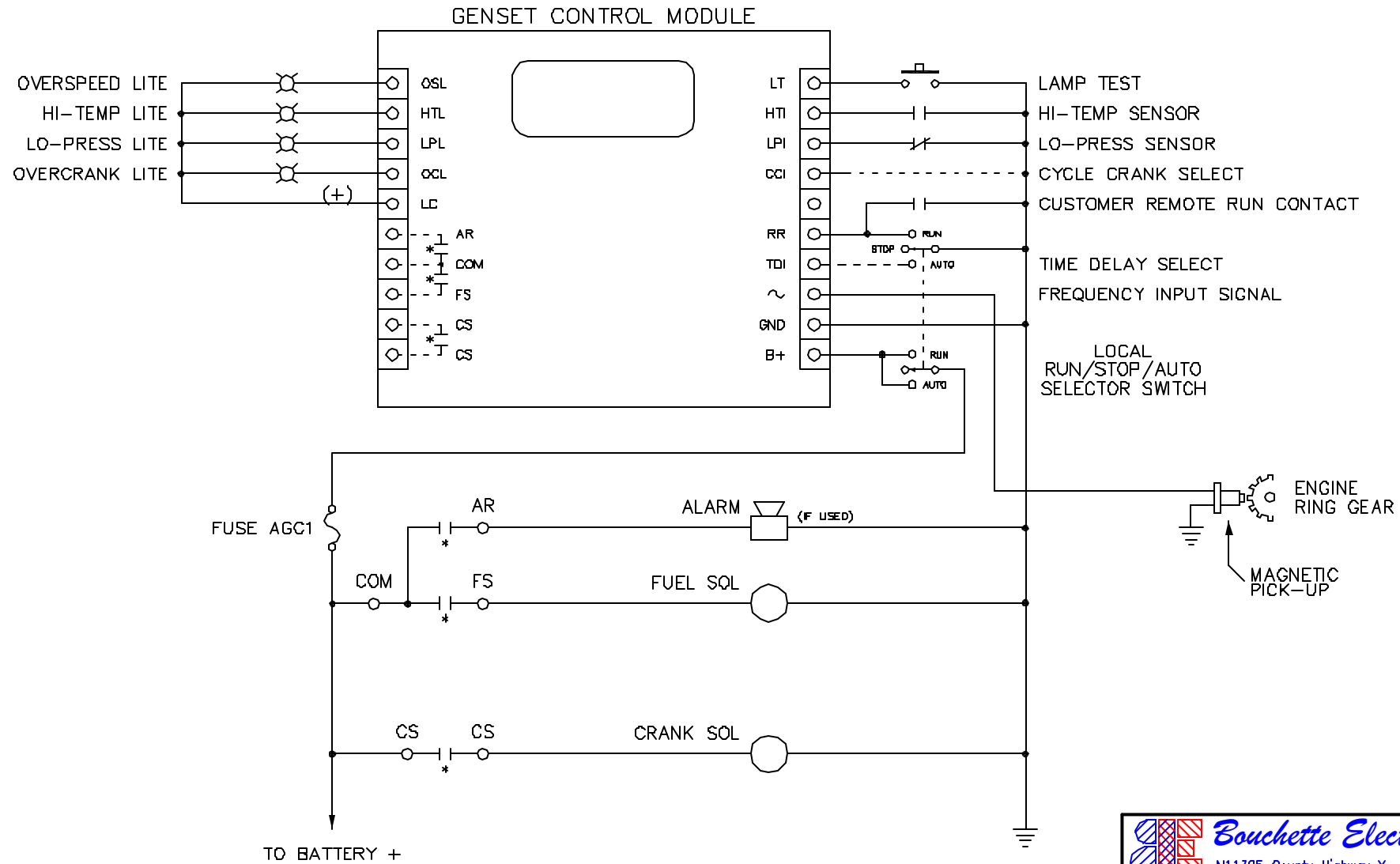

* RELAYS AR, FS,
& CS ARE INSIDE THE
GENSET CONTROL.

FREQUENCY SENSING FROM MAGNETIC PICK-UP

 Bouchette Electronics, Inc. N11325 County Highway Y Clintonville, WI 54929			
TITLE CONNECTION DIAGRAM A121H/A241H CONTROL			
DATE	DWN BY	CHK	SCALE
10/09/03	DSB	TJB	NONE
P/N	CAD REF	DWG NO	E218-4