

GENSET CONTROL MODULE—LEVEL 2

A122A / A242A

Features:

- Models for both 12V and 24V systems.
- One model for both spark ignition and diesel engines.
- 7-alarm light outputs with lamp-test and alarm silence provisions.
- Approach (pre-alarm) inputs.
- User selectable starting mode: full cycle cranking, or single-cycle crank limiter.
- User adjustable time delays for engine start and engine stop (cool down).
- Loss of speed signal protection for crank motor circuit.
- Special logic to re-establish cranking following a false start.
- Special logic permits re-starting of hot engine.
- Lamp test provisions for external Emergency Stop light.
- Provisions to set overspeed trip point at rated generator frequency.
- Pluggable terminal blocks for ease in installation.

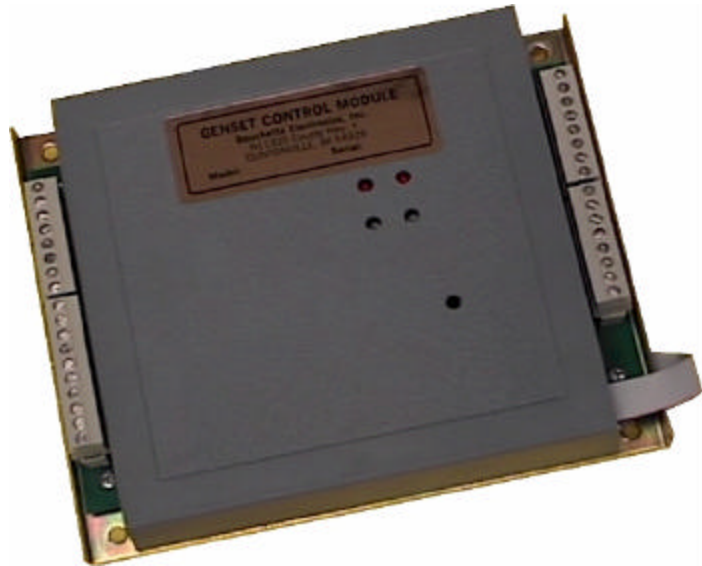

Shown with optional Data-Link for use with Interface Adapter

General Description:

The Genset Control Module is a microprocessor based control system which provides complete automatic control of standby generator set engines. Fuel solenoid and/or ignition control, cranking control, and audible alarm control are via heavy duty industrial type relay contacts. Engine temperature and oil pressure monitoring are obtained from engine mounted sensor contacts. Adjustable overspeed shutdown and crank termination control are provided internally via a frequency monitoring input terminal. This input signal may be obtained from any frequency source related to engine speed: distributor ignition pulses, magnetic pick-up, A.C. tachometer generator, alternator tachometer terminal, etc. One spare input and one spare output are available for special customer program requirements. Unless otherwise specified, this spare is shipped programmed as a 5th shutdown and alarm light output.

A122A / A242A Specifications

Input Voltage: Model A122A: 12VDC nominal, 16VDC max; transient and reverse polarity protected. (Typical: Pickup at 10VDC, Dropout at 6VDC.)

Model A242A: 24VDC nominal, 32VDC max; transient and reverse polarity protected. (Typical: Pickup at 14VDC, Dropout at 9VDC.)

Supply Current: 0.4A maximum plus alarm light burden.

Relay Load Contacts: FS & CS: 10A at 28VDC, inductive; AR: 2A at 28VDC, resistive.

Alarm Light Load: 150mA maximum each output (incandescent inrush is permitted.)

Shutdown Input Contacts: 3 (See operating instructions for start-up override times.)

Approach Input Contacts: 2 (See operating instructions for start-up override times.)

Frequency Input: 80V RMS max. (See note 1.)

Overspeed trip point is adjustable from;

A122A: 40 to 800Hz. (Ignition / Alternator Pick-up)

A122A2 / **A242A:** 350 to 1100Hz or 1750 to 5000Hz. (Alternator / Mag. Pick-up)

A122A1 / A242A1: 430 to 1350Hz or 2380 to 6800Hz. (Alternator / Mag. Pick-up)

Crank Disconnect Frequency: Internally fixed at 30% of the overspeed setting.

Crank Control: Single-cycle crank limiter: continuous 48 sec. crank period (non-adjustable.)

Cycle cranking: 5 cycles of 12 sec. crank and 12 sec. rest (non-adjustable.)

Time Delays: Delay on start from remote signal: 0-36 seconds (adjustable.)

Delay on shutdown from remote signal: 0-12 minutes (adjustable.)

Shielding: Internal EMI shielding provided.

Ambient Temperature: -25° F to +140° F

Finish: PC Board: Protected with moisture/fungus proof varnish.

Chassis: Zinc plated / yellow dichromate.

Cover: ABS plastic.

Terminal Blocks: Industrial vertical plug-in type header for ease in installation.

Note 1: Other models available for other frequencies and/or voltages.

Consult factory with your specific requirements.

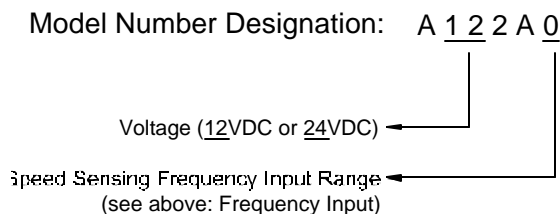

Bouchette Electronics, Inc.

N11325 County Highway Y, Clintonville, WI 54929
(715) 823-7770 (715) 823-7771 Fax www.bouchette.com

A122A / A242A Dimensions

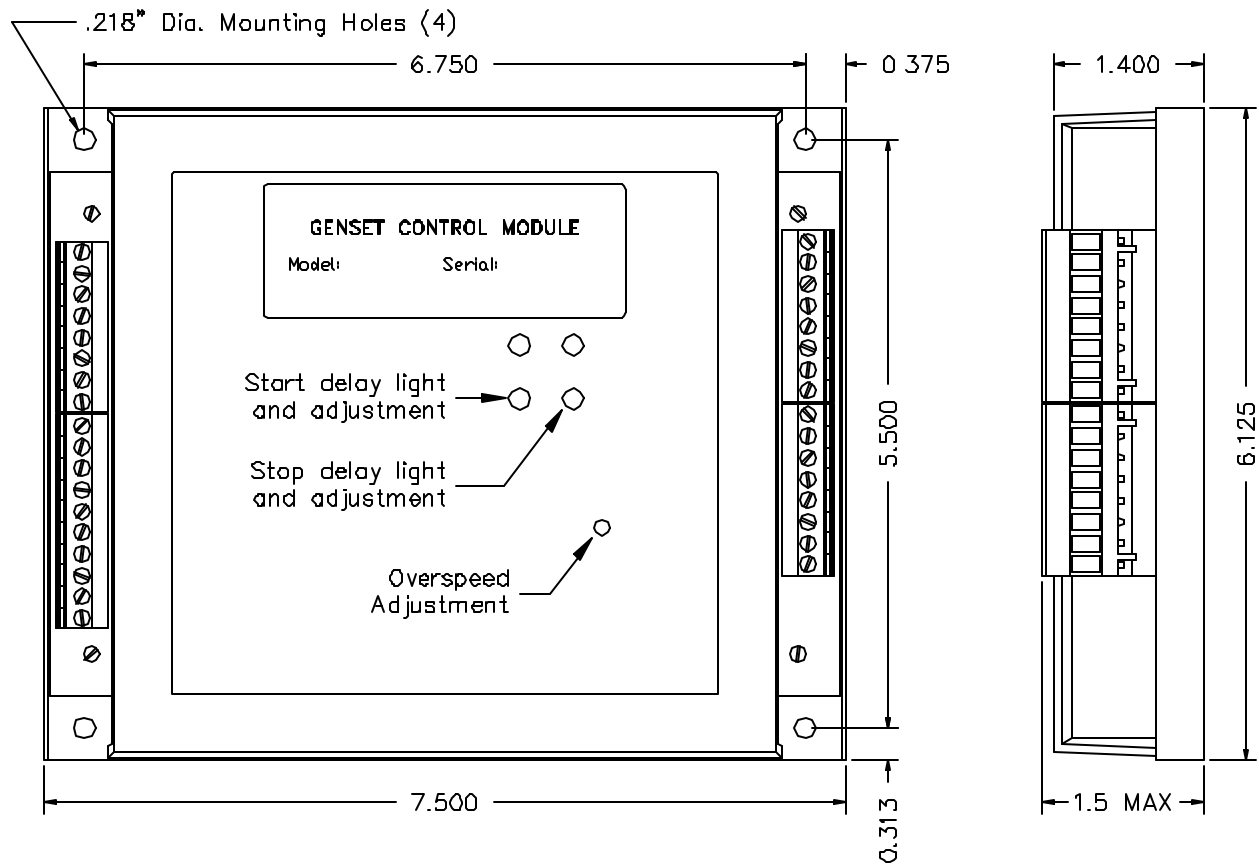

Bouchette Electronics, Inc.

N11325 County Highway Y, Clintonville, WI 54929
(715) 823-7770 (715) 823-7771 Fax www.bouchette.com

GENSET CONTROL MODULE — LEVEL 2

A122A / A242A

Control Switch Inputs

The following operator panel controls are wired into the microprocessor through the front-mounted terminal blocks:

1. Run/Stop/Auto Switch.

a. “Run” position causes the engine to start and run immediately.

b. “Auto” position allows the unit to be controlled via any remote single-pole dry-type contact (transfer switch, remote start switch, etc.). Contact closure causes the unit to start and run, while contact opening causes the unit to shut down. *Also see Start/Stop Time Delays for time delay options.*

c. “Stop” position de-energizes the control module for immediate shutdown.

2. Lamp Test Push-Button.

Energizes all alarm lights simultaneously. This feature is disabled with the Run/Stop/Auto switch in the “Stop” position, and has no other effect on unit operation. This switch must be in the “Auto” position to test the System Normal Light (SNL).

3. Alarm Silence Push-Button.

De-energizes the alarm relay at any time and changes the status of the alarm lights from flashing to continuous ‘on’. Any subsequent faults will re-energize the alarm.

Relay Functions

1. Master Control Relay (FS).

Operates the fuel solenoid, etc.

2. Cranking Control Relay (CS).

Controls engine cranking functions.

3. Alarm Relay (AR).

Provides contact (2-amp. maximum) for remote alarm indication, bell, etc. The alarm relay is energized for all engine fault conditions.

Operating Instructions

Safety Inputs

1. Low Oil Pressure (LOP) Shutdown.

Monitoring of oil pressure begins 12-seconds after the unit starts and remains in effect until the unit is shut down (*except as noted in section Microprocessor Program Notes.*) Except as noted, closure of this contact while engine is running results in engine fault shutdown and alarm with light indication. The LOP signal is derived from an oil pressure sensor switch mounted on the engine.

2. High Water Temperature (HWT) Shutdown.

The engine coolant temperature sensor monitoring begins immediately with the start signal. However, if the water temperature is excessive prior to start, (i.e., heat soak after shutdown), the unit is permitted to start and the high temperature condition is permitted to exist for up to 60-seconds after the unit is running, before an engine fault shutdown and alarm with light indication occurs. If the high temperature condition is corrected within that time period, the microprocessor circuit reverts to normal monitoring. Except as noted, closure of this contact while engine is running results in engine fault shutdown and alarm with light indication. The HWT signal is derived from a temperature sensor switch mounted on the engine.

3. Spare Shutdown (Optional).

Monitoring of the spare input begins 12-seconds after the unit starts and remains in effect until the unit is shut down. Closure of this contact while running results in engine fault shutdown and alarm with light indication. If used, this input is derived from a sensor switch external to the control module.

4. Overspeed (OS) Shutdown / Adjustment.

Overspeed shutdown protection is provided by a frequency sensing network within the control module. The trip point of the frequency network is screwdriver adjustable through the opening in the face of the control module as shown. Clockwise rotation increases the trip frequency and thereby, raises the shutdown speed. Exceeding this speed will result in engine fault shutdown and alarm with light indication. (*Also see Special Test Input for adjusting the OS trip point.*)

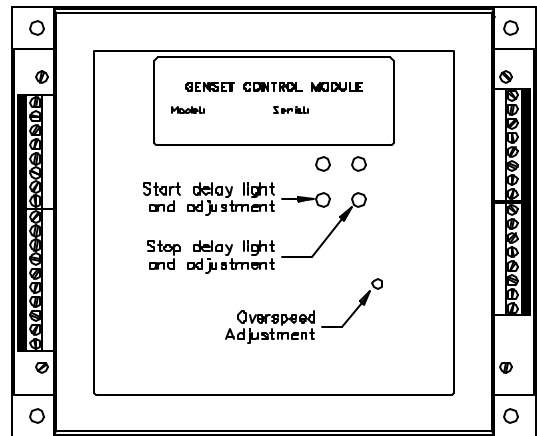

Genset Control Module - Face

5. Approach Alarms (Pre-Alarms)

The control module also accepts one additional input for both LOP & HWT. Closure of either of these contacts while engine is running results in alarm with respective light indication, without shutting the unit down. This permits detection of an impending shutdown and is intended to warn that a shutdown may occur. Each alarm light will self-extinguish as its approach fault is corrected. The alarm relay will automatically de-energize if all alarm lights are extinguished. *Also see section Alarm Silence Push-Button.* If used, these inputs are connected to the engine mounted sensor switches similar to those used for the shutdown feature.

Special Test Input

The OS test input may be used to assist setting the overspeed trip point:

- a. Temporarily ground the “OS Test” terminal.

- b. Turn the overspeed adjustment clockwise several turns until the engine can be operated at 60Hz without an “overspeed” engine fault shutdown.

- c. Operate the engine at exactly 60Hz and slowly turn the overspeed adjustment counter-clockwise until the engine shuts down with an “overspeed” engine fault.

- d. Remove ground from the “OS Test” terminal. The OS trip point is now set at 69Hz (115% rated) and needs no further adjustment.

Start/Stop Time Delays

The control module provides screwdriver adjustable time delays for starting and/or stopping the unit. If used, the start delay will delay the start-up of the engine for 0-36 seconds after the Remote Run contact is closed. The stop delay will delay the shutdown of the engine for 0-12 minutes after the Remote Run contact is opened. These timing features can be made active only in the “Auto” switch position, and still permits instantaneous manual starting in the “Run” switch position. Placing the selector switch in the “Stop” position provides instantaneous shutdown of the engine under all conditions. The start delay is intended to prevent unnecessary start-ups from momentary remote run signals, and the stop delay is intended to provide a cool-off running period for the engine after load removal. Each timing function has a red light located on the control module face to indicate when in use. Clockwise rotation increases time delay.

Cranking Control

1. Overcrank (OC) Protection.

Two different cranking cycles are programmed into the control modules microprocessor:

a. Single-Cycle Cranking Feature.

This feature provides a single, non-adjustable, crank period of 48-seconds. Failure of the engine to start within that time results in an “overcrank” engine fault shutdown and alarm with light indication.

b. Cycle Cranking Feature.

The control module may be field-converted to the “cycle cranking” feature by grounding the “CCI” terminal on the control. This feature provides a series of five cranking cycles; each containing a 12-second crank period with a 12-second rest period. Failure of the engine to start by the end of the fifth crank period results in an “overcrank” engine fault shutdown and alarm with light indication.

2. Cranking Disconnect

The cranking termination speed is obtained from the frequency network within the control module. The microprocessor automatically sets the cranking termination speed at 30% of the selected overspeed trip value.

3. Loss of Frequency Signal

The microprocessor will detect an absence of frequency signal while cranking. After the first 12-seconds of cranking, the “overcrank” light begins a staggered flashing pattern to indicate there is no frequency signal input.

If the cycle cranking feature (*1.b above*) was selected; the microprocessor automatically converts to the single-cycle cranking feature (*1.a above*). This conversion prevents the starter motor from re-engaging during the second crank cycle in the event the engine is already running. *Also see section Microprocessor Program Notes.*

Microprocessor Program Notes

Internal protection against loss of frequency input signal is programmed in after the unit has started normally. In the event the frequency goes to zero (engine runs out of fuel, frequency signal source fails, etc.), the LOP shutdown circuit is bypassed and a 12-second wait period is initiated. If the frequency returns within this time period, LOP monitoring resumes and operation continues normally. If frequency has not returned at the end of this time period, the engine oil pressure status is observed to determine whether the engine is actually running or stopped. If the engine has stopped, the cranking cycle will begin in an effort to re-start the engine. If the engine has not stopped (loss of input signal, etc.), the unit will display an “overcrank” indication and alarm, and will continue to run **WITHOUT OVERSPEED PROTECTION** until stopped in a normal manner. Re-starting at a later time is prevented until the “overcrank” indication has been reset.



Warning: “Overcrank” indication can mean a loss of frequency input signal during the previous run period. Attempting to re-start the engine without any frequency input signal can destroy the starter motor, which can cause serious personal injury. The frequency signal source is a key component in this system and must be checked out thoroughly whenever an “overcrank” shutdown occurs.

Resetting A Fault Shutdown

A shutdown with alarm, due to any fault condition, will prevent any subsequent operation of the generator set. The Run/Stop/Auto switch on the operator control panel must be momentarily placed in the “Stop” position to reset these functions.

Bouchette Electronics, Inc.

N11325 County Highway Y, Clintonville, WI 54929
(715) 823-7770 (715) 823-7771 Fax www.bouchette.com

GENSET CONTROL MODULE—LEVEL 1 & 2

Overspeed Selection Formula

The Genset manufacturer must determine the overspeed (OS) trip point based on maximum allowable speeds for both the engine and generator.

The following formula should be used to determine the OS trip frequency for any engine¹. Select a Genset Control model which OS frequency range includes the desired trip frequency.

- 1) All engines with magnetic pick-up sensing (*recommended*):

$$\text{OS Frequency} = 30 \times D \times (\text{number of teeth on ring gear})$$

- 2) All engines with belt-driven alternator sensing:

$$\text{OS Frequency} = 15 \times D \times (\text{number of alt. poles}) \times \frac{(\text{drive pulley diameter})}{(\text{alt. pulley diameter})}$$

- 3) All engines with flywheel-type alternator sensing:

$$\text{OS Frequency} = 15 \times D \times (\text{number of alternator poles})$$

- 4) Gasoline engines only, with distributor ignition sensing:

$$\text{OS Frequency} = 15 \times D \times \text{number of cylinders}$$

D = Speed Multiplier

i.e. If OS is set at @ 72Hz (on 60Hz generator),
then D = 1.2 (1.2 × 60Hz = 72Hz)

¹These formulae are for nominal 1800 RPM engines; for 3600 RPM engines, the calculated OS frequency should be doubled.

Bouchette Electronics, Inc.

GENSET CONTROL MODULE—A121 / A122

Overspeed Set-Up Instructions



Before installing the Genset Control Module, the proper input frequency range needs to be selected as described below.

Through a hole in the back of each control (as shown in diagram below), jumper wire(s) are used to select the input frequency range. Locate your model number on the following charts for the correct range settings.

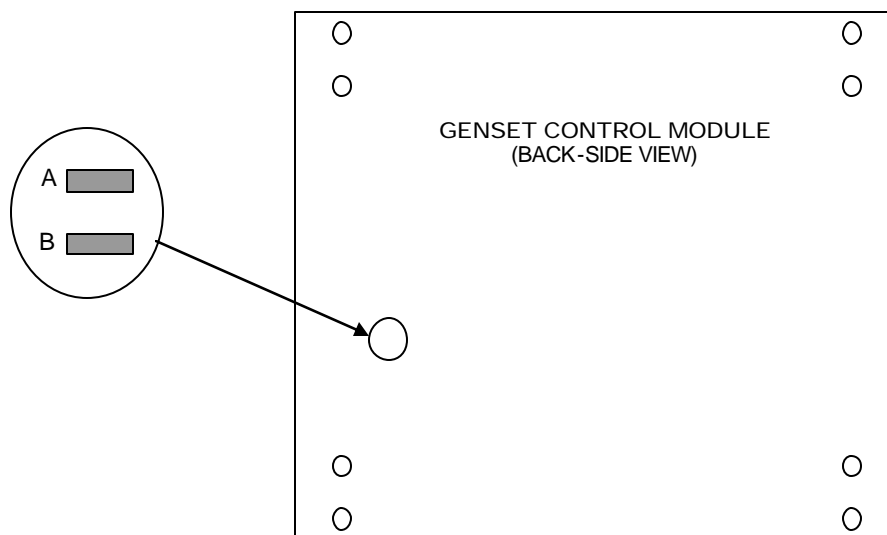

Caution: When cutting jumper wires, do not allow ends of jumper wire to come in contact with other components or the chassis. Completely remove the jumper wire, or cut in the middle and separate ends about 1/8".

Bouchette Electronics, Inc.

N11325 County Highway Y, Clintonville, WI 54929
(715) 823-7770 (715) 823-7771 Fax www.bouchette.com

Important Notice

OVERSPEED MODEL SELECTION—A121 / A122

<u>Available Models</u>					
A121A1	A121B1	A121C1	A121CB1	A122A1	A122D1
A122E1	A241A1	A241B1	A241C1	A241CB1	A242A1
		A242D1	A242E1		
<u>Typical Frequency Input Sources</u>					
Magnetic Pick-up					
Alternator tachometer terminal					
Tachometer generator					
At engine overspeed, the Input Frequency is between:			Cut these Jumper Wires		
430 - 1350 Hz			None		
2380 - 6800 Hz			"A" Only		

<u>Available Models</u>					
A121A2	A121B2	A121C2	A121CB2	A122A2	A122D2
A122E2	A241A	A241B	A241C	A241CB	A242A
		A242D	A242E		
<u>Typical Frequency Input Sources</u>					
Magnetic Pick-up					
Alternator tachometer terminal					
Tachometer generator					
At engine overspeed, the Input Frequency is between:			Cut these Jumper Wires		
350 - 1100 Hz			None		
1750 - 5000 Hz			"A" Only		

<u>Available Models</u>					
A121A	A121B	A121C	A121CB	A122A	A122D
					A122E
<u>Typical Frequency Input Sources</u>					
Alternator tachometer terminal					
Distributor low-voltage input terminal					
At engine overspeed, the Input Frequency is between:			Cut these Jumper Wires		
28 - 90 Hz			None		
78 - 240 Hz			"A" Only		
200 - 600 Hz			"B" Only		
250 - 800 Hz			"A" and "B"		

Bouchette Electronics, Inc.

N11325 County Highway Y, Clintonville, WI 54929
 (715) 823-7770 (715) 823-7771 Fax www.bouchette.com

GENSET CONTROL MODULE

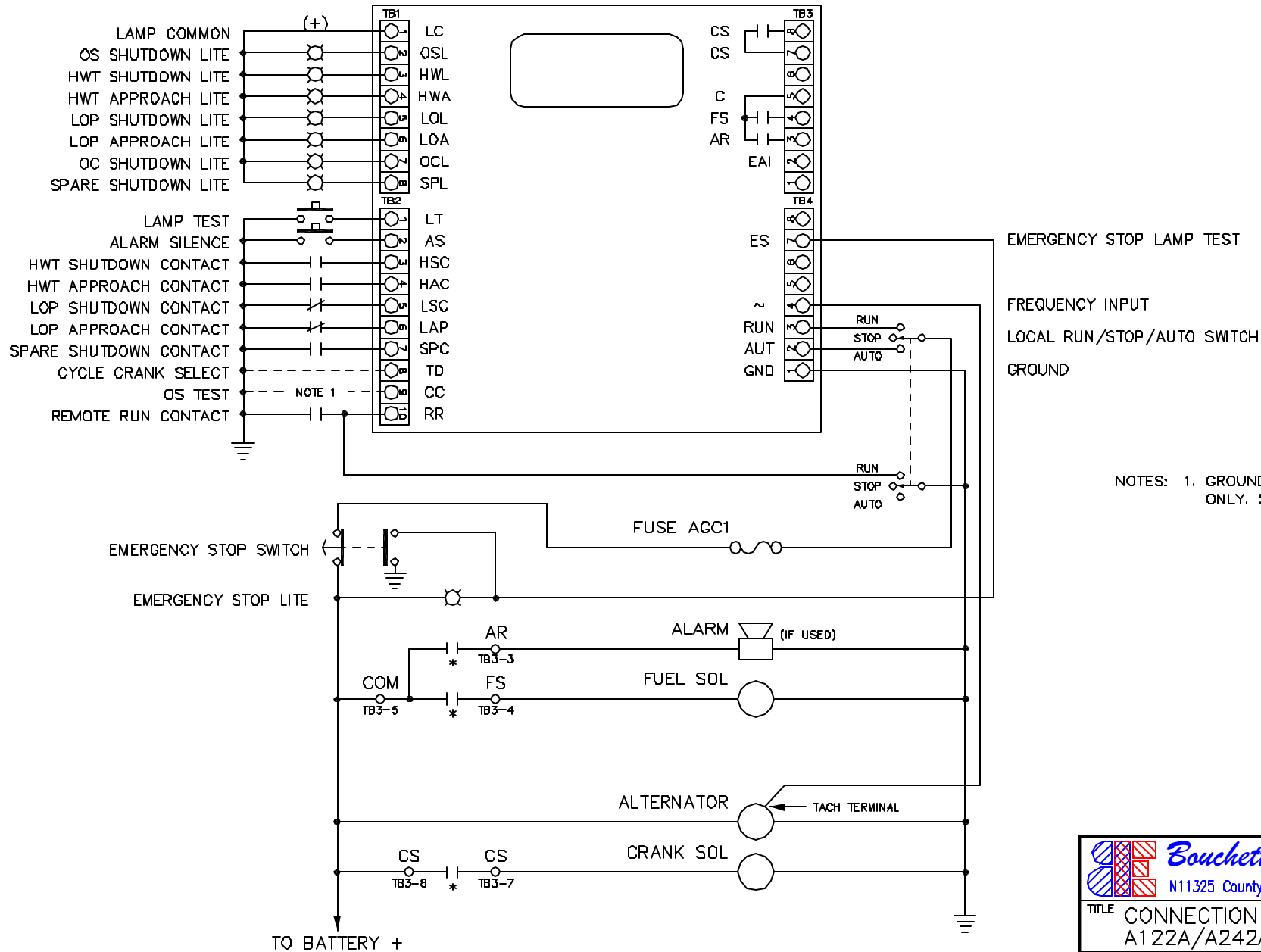

NOTES: 1. GROUND FOR OVERSPEED TEST ONLY. SEE OPERATING INSTRUCTIONS.

* RELAYS AR, FS, & CS ARE INSIDE THE GENSET CONTROL.

FREQUENCY SENSING FROM ALTERNATOR TACH. TERMINAL

Bouchette Electronics, Inc. N11325 County Highway Y Clintonville, WI 54929				
TITLE CONNECTION DIAGRAM A122A/A242A CONTROL				
DATE	DWN BY	CHK	SCALE	
08/23/04	DSB	TJB	NONE	
P/N	CAD REF	DWG NO		
	PCB109			E164-1

GENSET CONTROL MODULE

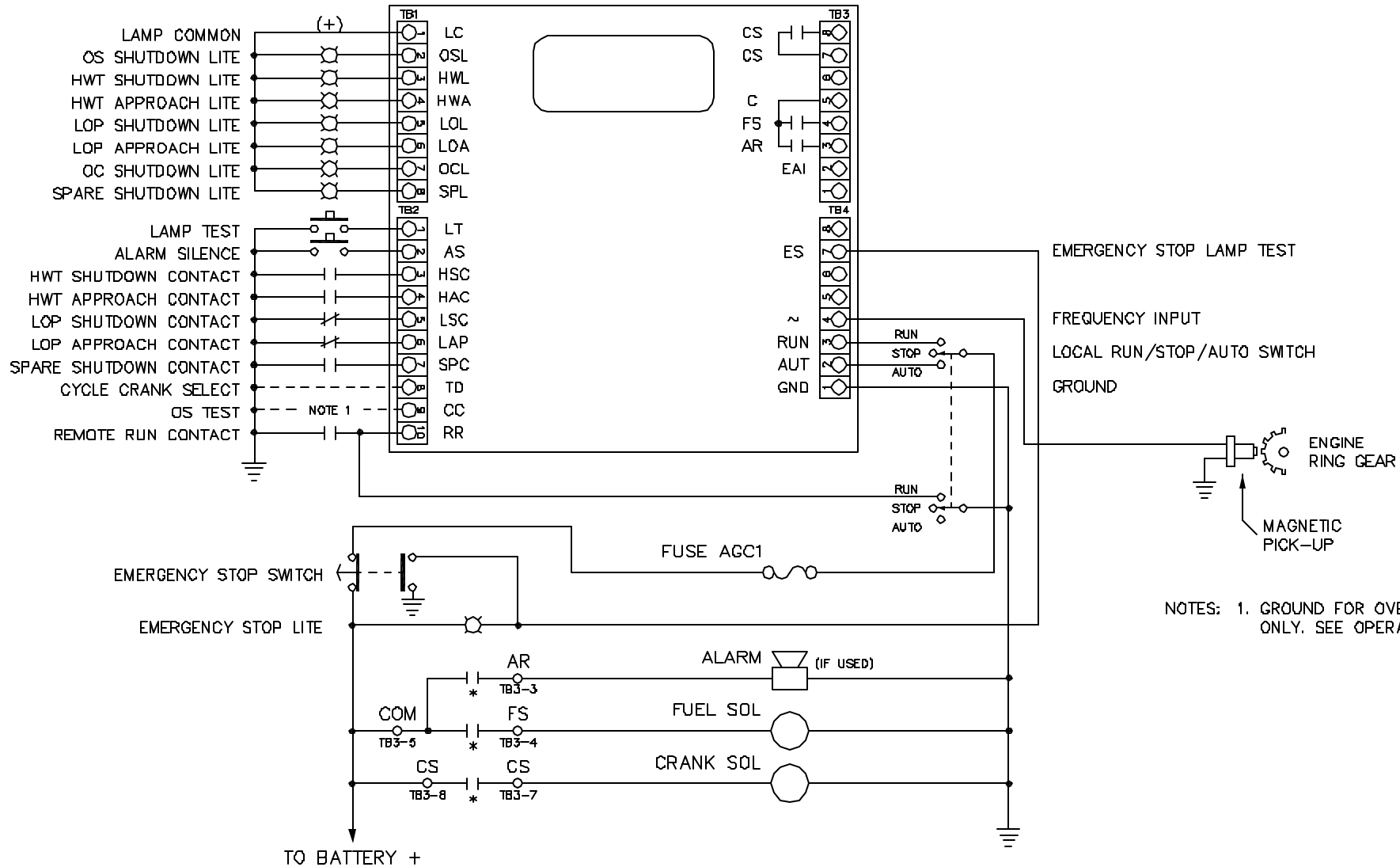

NOTES: 1. GROUND FOR OVERSPEED TEST ONLY. SEE OPERATING INSTRUCTIONS.

* RELAYS AR, FS, & CS ARE INSIDE THE GENSET CONTROL.

FREQUENCY SENSING FROM MAGNETIC PICK-UP

Bouchette Electronics, Inc. N11325 County Highway Y Clintonville, WI 54929			
TITLE CONNECTION DIAGRAM A122D2/A242D2 CONTROL			
DATE	DWN BY	CHK	SCALE
04/12/95	DSB	TJB	NONE
P/N	CAD REF	DWG NO	
	PCB109		E165-2