

GENSET CONTROL MODULE **C121B / C241B**

Features:

- Models for both 12V and 24V systems.
- One model for both spark ignition and diesel engines.
- 4-alarm light outputs with lamp-test provisions.
- Glow control output for engine pre-heat provisions.
- Loss of speed signal protection for crank motor circuit.
- Special logic to re-establish cranking following a false start.
- Special logic permits restarting of hot engine.

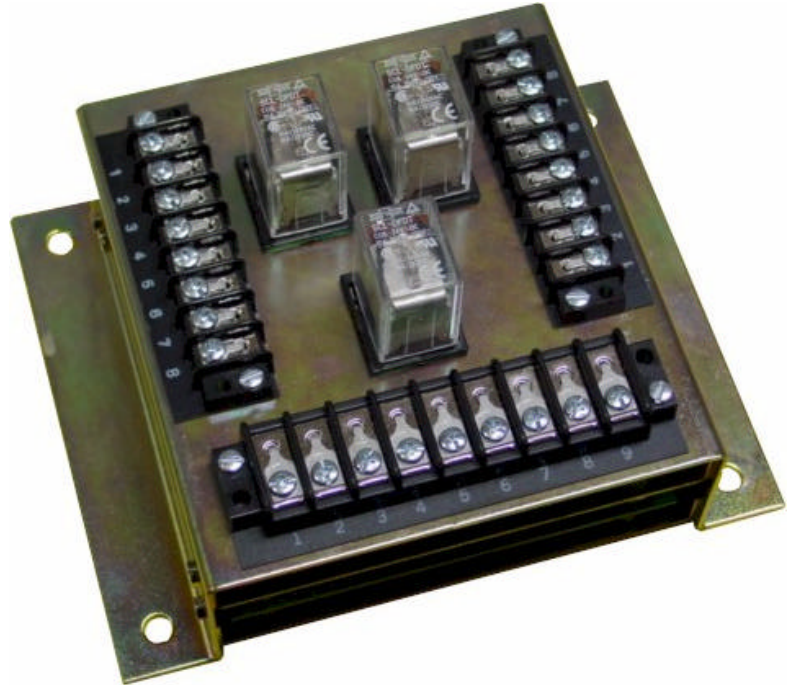

General Description:

The Genset Control Module is a microprocessor based control system which provides complete automatic control of standby generator set engines. Fuel solenoid and/or ignition control, cranking control, and audible alarm control are via heavy duty industrial type relay contacts. The pilot for glow control is provided via a solid state sourcing transistor. Engine temperature and oil pressure monitoring are obtained from engine mounted sensor contacts. Adjustable overspeed shutdown and crank termination control are provided internally via a frequency monitoring input terminal. This input signal may be obtained from any frequency source related to engine speed: distributor ignition pulses, magnetic pick-up, A.C. tachometer generator, alternator tachometer terminal, etc.

C121B / C241B Specifications

Input Voltage: Model C121B: 12VDC nominal, 16VDC max; transient and reverse polarity protected. (Typical: Pickup at 10VDC, Dropout at 6VDC.)

Model C241B: 24VDC nominal, 32VDC max; transient and reverse polarity protected. (Typical: Pickup at 14VDC, Dropout at 9VDC.)

Supply Current: 0.4A maximum plus alarm light burden.

Relay Load Contacts: MR & AR: 10A at 32VDC, resistive, (or 277VAC.)
AL: 20A at 32VDC, resistive.

Transistor Output: Sourcing output at 1A maximum. (pilot for glow control.)

Alarm Light Load: 150mA maximum each output (incandescent inrush is permitted.)

Shutdown Contact Inputs: 2 (See operating instructions for start-up override times.)

Frequency Input: 80V RMS max. (See note 1.)

Overspeed trip point is adjustable from;

C121B: 70 to 190Hz & 235 to 690Hz. (Distributor/Belt-driven Alternator)

C241B: 96 to 260Hz & 350 to 950Hz. (Distributor/Belt-driven Alternator)

C121B6/C241B6: 31 to 91Hz. (Distributor Ignition sensing)

C121B9/C241B9: 82 to 250Hz. (Distributor Ignition sensing)

C121B8/C241B8: 150 to 325Hz. (Flywheel Alternator sensing)

C121B3/C241B3: 550 to 1100Hz. (Belt-driven Alternator sensing (extended))

C121B2/C241B2: 1750 to 5000Hz. (Magnetic Pick-up sensing)

C121B1/C241B1: 2380 to 6800Hz. (Magnetic Pick-up sensing (extended))

Crank Disconnect Frequency: Internally fixed at 30% of the overspeed setting.

Crank Control: Single-cycle crank limiter: continuous 48 sec. crank period (non-adjustable.)

Cycle-cranking: 5 cycles of 12 sec. crank and 12 sec. rest (non-adjustable.)

Shielding: EMI shielding provided.

Ambient Temperature: -25° F to +140° F

Finish: PC Board: Protected with moisture/fungus proof varnish.

Chassis: Zinc plated / yellow dichromate.

Terminal Blocks: Industrial screw-terminal type.

Note 1: Other models available for other frequencies and/or voltages.

Consult factory with your specific requirements.

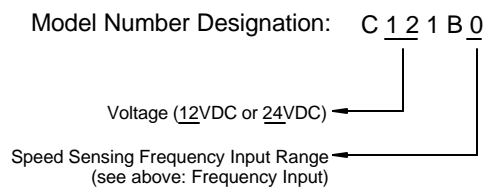

Bouchette Electronics, Inc.

C121B / C241B Dimensions

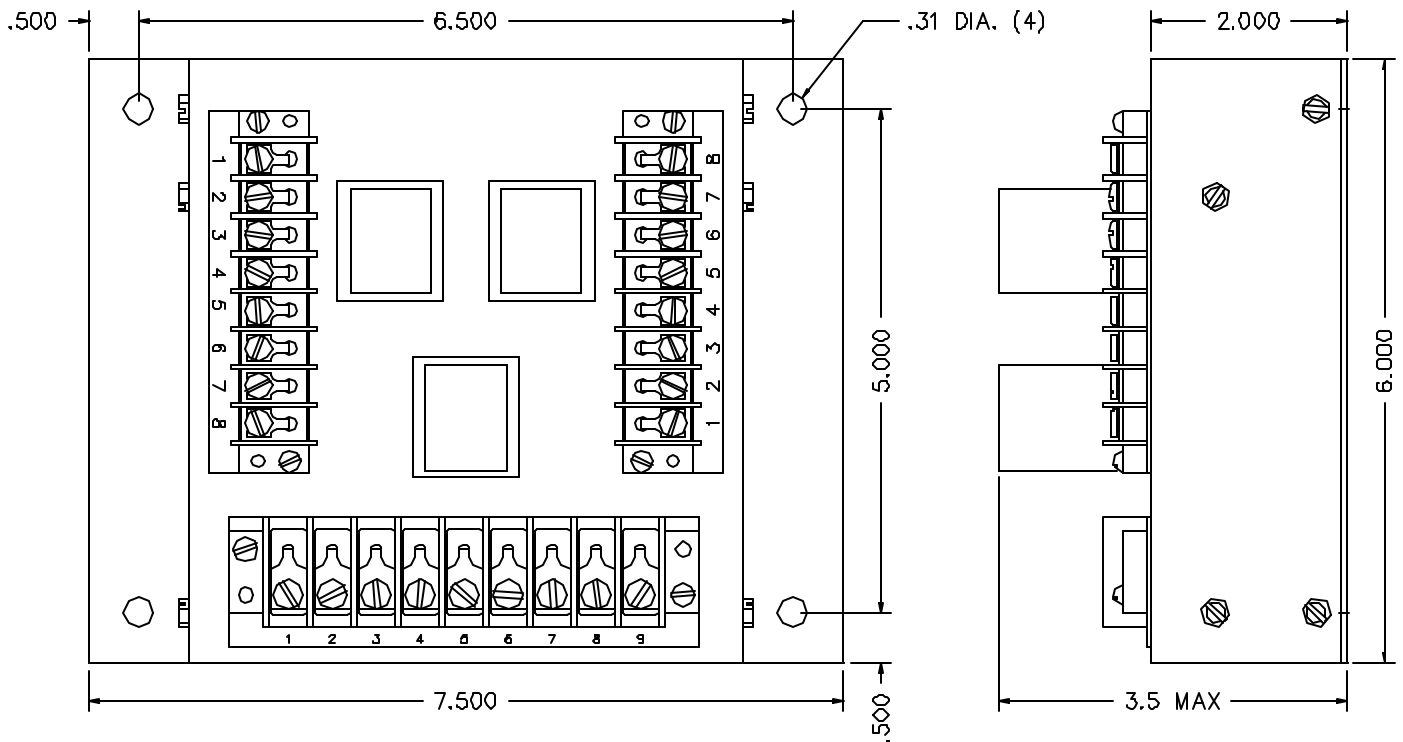

Bouchette Electronics, Inc.

N11325 County Highway Y, Clintonville, WI 54929
(715) 823-7770 (715) 823-7771 Fax www.bouchette.com

GENSET CONTROL MODULE — LEVEL 1

C121B / C241B

Control Switch Inputs

The following operator panel controls are wired into the microprocessor through the front-mounted terminal blocks:

1. Run/Stop/Auto Switch

- a. “Run” position causes the engine to start and run immediately.
- b. “Auto” position allows the unit to be controlled via any remote single-pole dry-type contact (transfer switch, remote start switch, etc.). Contact closure causes the unit to start and run, while contact opening causes the unit to shut down.
- c. “Stop” position de-energizes the control module for immediate shutdown.

2. Lamp Test Push-Button

Energizes all alarm lights simultaneously. This feature is disabled with the Run/Stop/Auto selector switch in the “Stop” position, and has no other effect on unit operation.

Output Functions

1. Master Control Relay (FS).

Operates the fuel solenoid, etc.

2. Cranking Control Relay (CS).

Controls engine cranking functions.

3. Alarm Relay (AR).

Provides isolated contact for remote alarm indication, bell, etc. The alarm relay is energized for all engine fault conditions.

4. Glow Control Transistor Output.

Sourcing output (1-amp. maximum) for pilot control of glow plugs.

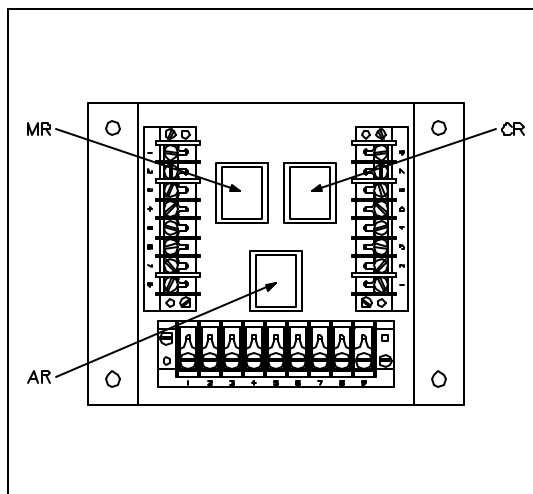

Figure 1. C121A Genset Control Module

Operating Instructions

Safety Inputs

1. Low Oil Pressure (LOP) Shutdown.

Monitoring of oil pressure begins 12-seconds after the unit starts and remains in effect until the unit is shut down (*except as noted in section Microprocessor Program Notes.*) Except as noted, closure of this contact while engine is running results in engine fault shutdown and alarm with light indication. The LOP signal is derived from an oil pressure sensor switch mounted on the engine.

2. High Water Temperature (HWT) Shutdown.

The engine coolant temperature sensor monitoring begins immediately with the start signal. However, if the water temperature is excessive prior to start, (i.e., heat soak after shutdown), the unit is permitted to start and the high temperature condition is permitted to exist for up to 60-seconds after the unit is running, before an engine fault shutdown and alarm with light indication occurs. If the high temperature condition is corrected within that time period, the microprocessor circuit reverts to normal monitoring. Except as noted, closure of this contact while engine is running results in engine fault shutdown and alarm with light indication. The HWT signal is derived from a temperature sensor switch mounted on the engine.

3. Overspeed (OS) Shutdown / Adjustment.

Overspeed shutdown protection is provided by a frequency sensing network within the control module. The trip point of the frequency network is screwdriver adjustable via a rheostat accessible through the top of the control module as shown. Clockwise rotation increases the trip frequency and thereby, raises the shutdown speed. Exceeding this speed will result in engine fault shutdown and alarm with light indication.

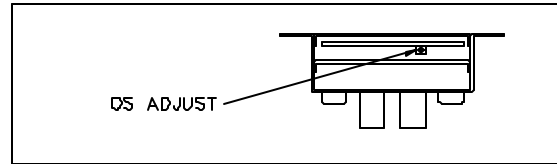

Figure 2. Genset Control Module OS-Adjustment

Glow Cycle Select

A glow plug cycle of 24-seconds can be introduced each time the engine is started by cutting the jumper wire located through the access hole nearest the middle of the back of the control module as shown. The glow period energizes the glow plugs prior to cranking, therefore delaying startup of the engine for 24-seconds.

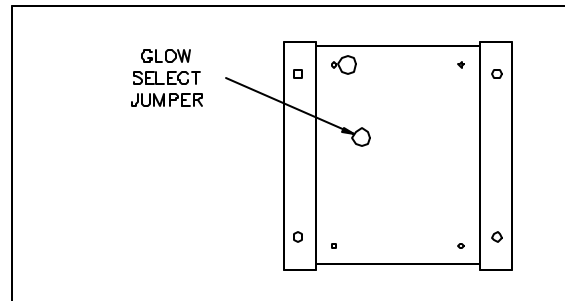

Figure 3. Genset Control Module Backside

Cranking Control

1. Overcrank (OC) Protection.

The cycle cranking feature provide a series of five cranking cycles; each containing a 12-second crank period with a 12-second rest period. Failure of the engine to start by the end of the fifth crank period results in an “overcrank” fault shutdown and alarm with light indication.

2. Cranking Disconnect

The cranking termination speed is obtained from the frequency network within the control module. The microprocessor automatically sets the cranking termination speed at 30% of the selected overspeed trip value.

Microprocessor Program Notes

Internal protection against loss of frequency input signal is programmed in after the unit has started normally. In the event the frequency goes to zero (engine runs out of fuel, frequency signal source fails, etc.), the LOP shutdown circuit is bypassed and a 12-second wait period is initiated. If the frequency returns within this time period, LOP monitoring resumes and operation continues normally. If frequency has not returned at the end of this time period, the engine oil pressure status is observed to determine whether the engine is actually running or stopped. If the engine has stopped, the cranking cycle will begin in an effort to restart the engine. If the engine has not stopped (loss of input signal, etc.), the unit is shutdown with an “overcrank” engine fault and alarm with light indication.

Warning: “Overcrank” indication can mean a loss of frequency input signal during the previous run period. Attempting to restart the engine without any frequency input signal can destroy the starter motor, which can cause serious personal injury. The frequency signal source is a key component in this system and must be checked out thoroughly whenever an “overcrank” shutdown occurs, since the control module only provides an indication of loss of signal during startup.

Resetting A Fault Shutdown

A shutdown with alarm, due to any fault condition, will prevent any subsequent operation of the generator set. The Run/Stop/Auto selector switch on the operator control panel must be momentarily placed in the “Stop” position to reset these functions.

Bouchette Electronics, Inc.

N11325 County Highway Y, Clintonville, WI 54929
(715) 823-7770 (715) 823-7771 Fax www.bouchette.com

Operating Instructions

Microprocessor Program Notes

Internal protection against loss of frequency input signal is programmed in after the unit has started normally. In the event the frequency goes to zero (engine runs out of fuel, frequency signal source fails, etc.), the LOP shutdown circuit is bypassed and a 12-second wait period is initiated. If the frequency returns within this time period, LOP monitoring resumes and operation continues normally. If frequency has not returned at the end of this time period, the engine oil pressure status is observed to determine whether the engine is actually running or stopped. If the engine has stopped, the cranking cycle will begin in an effort to restart the engine. If the engine has not stopped (loss of input signal, etc.), the unit is shutdown with an “overcrank” engine fault and alarm with light indication.

Warning: “Overcrank” indication can mean a loss of frequency input signal during the previous run period. Attempting to restart the engine without any frequency input signal can destroy the starter motor, which can cause serious personal injury. The frequency signal source is a key component in this system and must be checked out thoroughly whenever an “overcrank” shutdown occurs, since the control module only provides an indication of loss of signal during startup.

Resetting A Fault Shutdown

A shutdown with alarm, due to any fault condition, will prevent any subsequent operation of the generator set. The Run/Stop/Auto selector switch on the operator control panel must be momentarily placed in the “Stop” position to reset these functions.

Bouchette Electronics, Inc.

N11325 County Highway Y, Clintonville, WI 54929
(715) 823-7770 (715) 823-7771 Fax www.bouchette.com

GENSET CONTROL MODULE—LEVEL 1 & 2

Overspeed Selection Formula

The Genset manufacturer must determine the overspeed (OS) trip point based on maximum allowable speeds for both the engine and generator.

The following formula should be used to determine the OS trip frequency for any engine¹. Select a Genset Control model which OS frequency range includes the desired trip frequency.

- 1) All engines with magnetic pick-up sensing (*recommended*):

$$\text{OS Frequency} = 30 \times D \times (\text{number of teeth on ring gear})$$

- 2) All engines with belt-driven alternator sensing:

$$\text{OS Frequency} = 15 \times D \times (\text{number of alt. poles}) \times \frac{(\text{drive pulley diameter})}{(\text{alt. pulley diameter})}$$

- 3) All engines with flywheel-type alternator sensing:

$$\text{OS Frequency} = 15 \times D \times (\text{number of alternator poles})$$

- 4) Gasoline engines only, with distributor ignition sensing:

$$\text{OS Frequency} = 15 \times D \times \text{number of cylinders}$$

D = Speed Multiplier

i.e. If OS is set at @ 72Hz (on 60Hz generator),
then D = 1.2 (1.2 × 60Hz = 72Hz)

¹These formulae are for nominal 1800 RPM engines; for 3600 RPM engines, the calculated OS frequency should be doubled.

Bouchette Electronics, Inc.

GENSET CONTROL MODULE—C121 / C122

Overspeed Set-Up Instructions



Before installing the Genset Control Module, the proper input frequency range needs to be selected as described below. This notice applies only to models C121x and C122x without numeric suffix (shown below). Models that have a suffix (i.e. C122A2) have a dedicated frequency range with no selection jumper (following page).

Available Models			
C121A	C121B	C121C	C121D
C122A	C122B	C122D	C122E
<u>Typical Frequency Input Sources</u> Alternator tachometer terminal Distributor low-voltage input terminal			
At engine overspeed, the Input Frequency is between:		Cut these Jumper Wires	
70-190 Hz		None	
235-690 Hz		"A" Only	

Available Models			
C241A	C241B	C241C	C241D
C242A	C242B	C242D	C242E
<u>Typical Frequency Input Sources</u> Alternator tachometer terminal Distributor low-voltage input terminal			
At engine overspeed, the Input Frequency is between:		Cut these Jumper Wires	
96-260 Hz		None	
350-950 Hz		"A" Only	

Through a hole in the back of each control (as shown in diagram below), a jumper wire is used to select the input frequency range. Locate your model number on the preceding charts for the correct range settings.

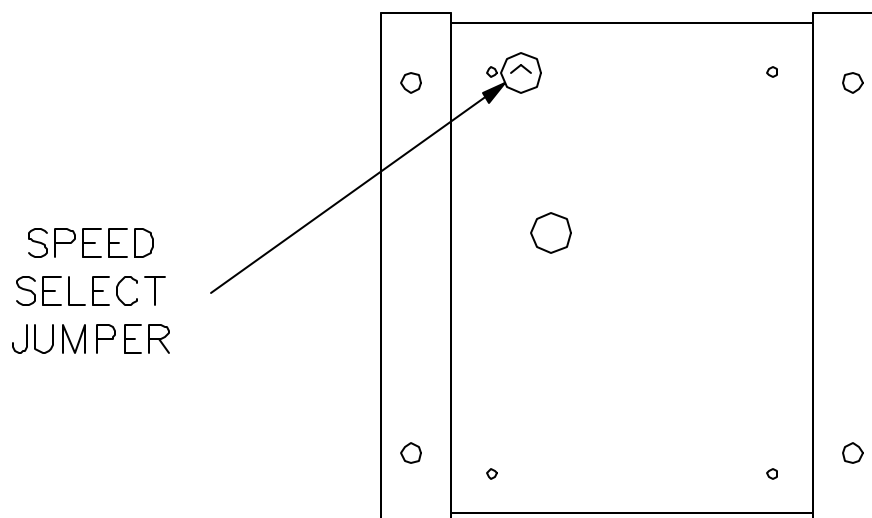

Caution: When cutting jumper wire, do not allow ends of jumper wire to come in contact with other components or the chassis. Completely remove the jumper wire, or cut in the middle and separate ends about 1/8".

Bouchette Electronics, Inc.

N11325 County Highway Y, Clintonville, WI 54929
 (715) 823-7770 (715) 823-7771 Fax www.bouchette.com

Important Notice

OVERSPEED MODEL SELECTION—C121 / C122

<u>Available Models</u>	<u>Typical Frequency Input Sources</u>	At engine overspeed, the Input Frequency is between:
C121x6 C241x6 C122x6 C242x6	Generator frequency (with step-down XFMR) Distributor ignition sensing (low-voltage terminal)	31 - 90 Hz
C121x9 C241x9 C122x9 C242x9	Distributor ignition sensing (low-voltage terminal) Flywheel alternator sensing	82 - 250 Hz
C121x8 C241x8 C122x8 C242x8	Flywheel alternator sensing	150 - 325 Hz
C121x0 C241x0 C122x0 C242x0	Belt-driven alternator sensing	235 - 690 Hz
C121x3 C241x3 C122x3 C242x3	Belt-driven alternator sensing (extended)	550 - 1100 Hz
C121x2 C241x2 C122x2 C242x2	Magnetic pick-up sensing	1750 - 5000 Hz
C121x1 C241x1 C122x1 C242x1	Magnetic pick-up sensing (extended)	2380 - 6800 Hz

Bouchette Electronics, Inc.

N11325 County Highway Y, Clintonville, WI 54929
(715) 823-7770 (715) 823-7771 Fax www.bouchette.com

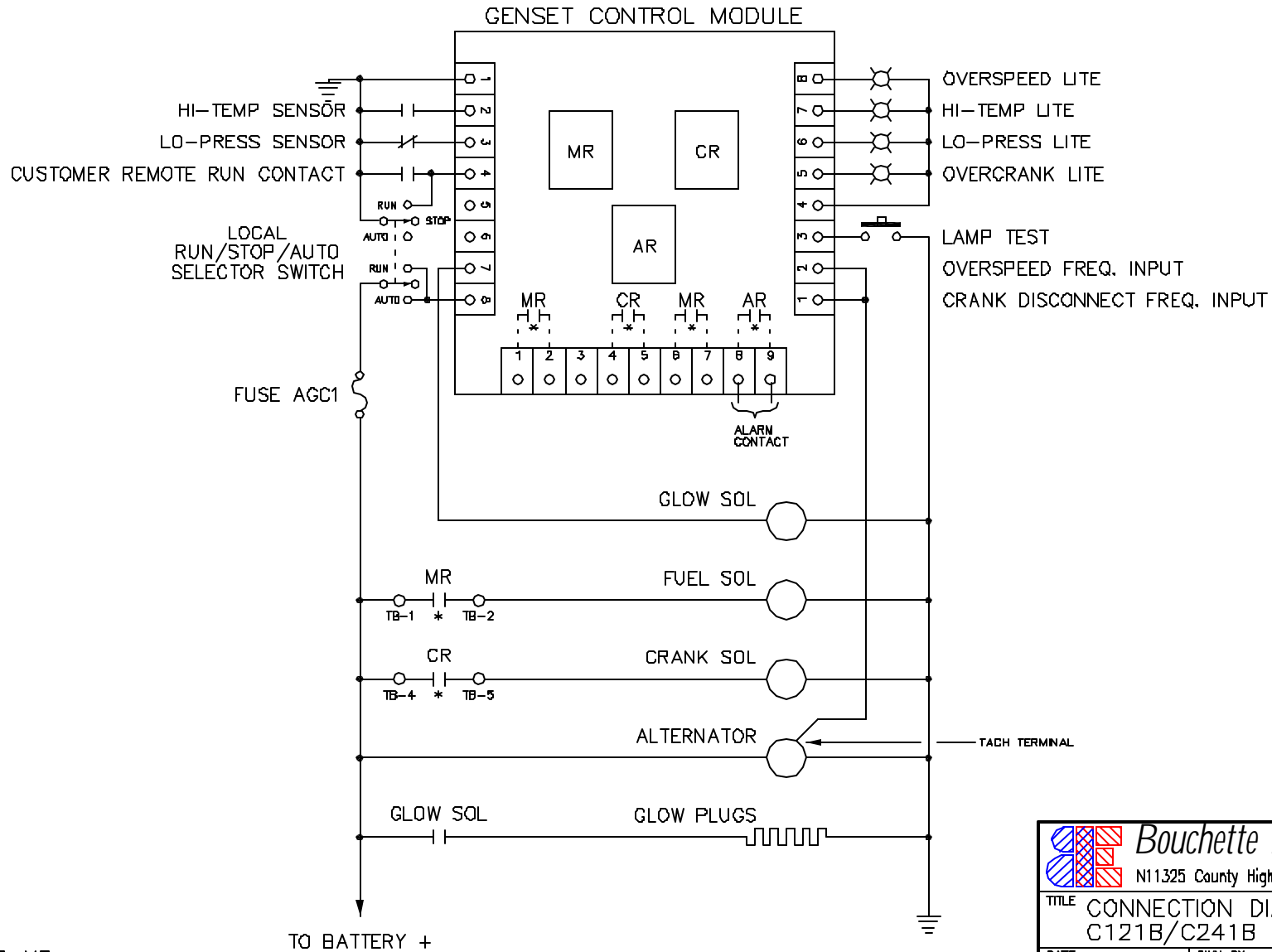

* RELAYS AR, MR,
& CR ARE INSIDE THE
GENSET CONTROL.

FREQUENCY SENSING FROM ALTERNATOR TACH. TERMINAL

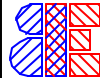
 Bouchette Electronics, Inc. N11325 County Highway Y Clintonville, WI 54929			
TITLE CONNECTION DIAGRAM C121B/C241B CONTROL			
DATE	DWN BY	CHK	SCALE
08/21/89	DSB	TJB	NONE
P/N	CAD REF	DWG NO	
			E116-5