

GENSET CONTROL MODULE—LEVEL 2

C122D / C242D

Features:

- Models for both 12V and 24V systems.
- One model for both spark ignition and diesel engines.
- 7-alarm light outputs with lamp-test and alarm silence provisions.
- Pre-alarm inputs and flashing “Off-Auto” light output per NFPA 110.
- User selectable starting modes: full cycle-cranking, or single-cycle crank limiter.
- User adjustable time delays for engine start and engine stop (cool down).
- Loss of speed signal protection for crank motor circuit.
- Special logic to re-establish cranking following a false start.
- Special logic permits restarting of hot engine.
- Lamp test provisions for external Emergency Stop and System Normal lights.

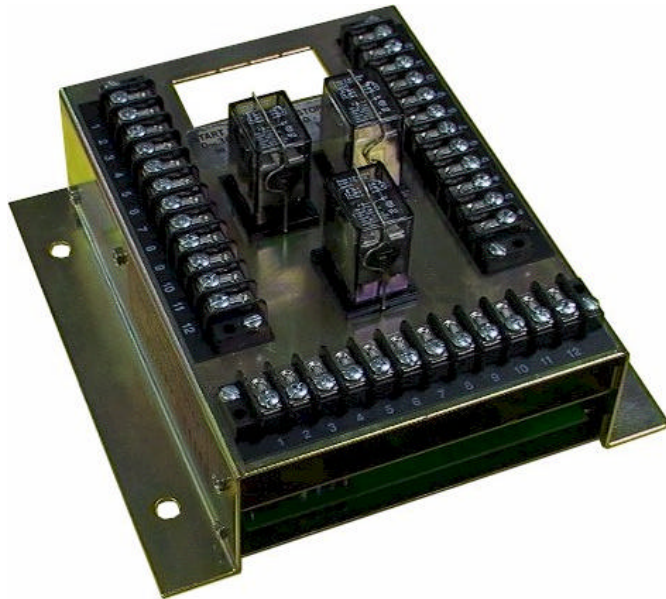

General Description:

The Genset Control Module is a microprocessor based control system which provides complete automatic control of standby generator set engines. Fuel solenoid and/or ignition control, cranking control, and audible alarm control are via heavy duty industrial type relay contacts. Engine temperature and oil pressure monitoring are obtained from engine mounted sensor contacts. Adjustable overspeed shutdown and crank termination control are provided internally via a frequency monitoring input terminal. This input signal may be obtained from any frequency source related to engine speed: distributor ignition pulses, magnetic pick-up, A.C. tachometer generator, alternator tachometer terminal, etc. One spare input and one spare output are available for special customer program requirements. Unless otherwise specified, this spare is shipped programmed as a 5th shutdown and alarm light output.

C122D / C242D Specifications

Input Voltage: Model C122D: 12VDC nominal, 16VDC max; transient and reverse polarity protected. (Typical: Pickup at 10VDC, Dropout at 6VDC.)

Model C242D: 24VDC nominal, 32VDC max; transient and reverse polarity protected. (Typical: Pickup at 14VDC, Dropout at 9VDC.)

Supply Current: 0.4A maximum plus alarm light burden.

Relay Load Contacts: FS & AR: 10A at 32VDC, resistive, (or 277VAC.)
CS: 20A at 32VDC, (cranking motor solenoid.)

Alarm Light Load: 150mA maximum each output (incandescent inrush is permitted.)

Shutdown Contact Inputs: 3 (See operating instructions for start-up override times.)

Approach Contact Inputs: 2 (See operating instructions for start-up override times.)

Frequency Input: 80V RMS max. (See note 1.)

Overspeed trip point is adjustable from;

C122D / C242D: 250 to 800Hz. (Ignition / Alternator Pick-up)

C122D2 / C242D2: 1750 to 5000Hz. (Alternator / Mag. Pick-up)

Crank Disconnect Frequency: Internally fixed at 30% of the overspeed setting.

Crank Control: Single-cycle crank limiter: continuous 48 sec. crank period (non-adjustable.)

Cycle-cranking: 5 cycles of 12 sec. crank and 12 sec. rest (non-adjustable.)

Time Delays: Delay on start from remote signal: 0-36 seconds (adjustable.)

Delay on shutdown from remote signal: 0-12 minutes (adjustable.)

Shielding: Internal EMI shielding provided.

Ambient Temperature: -25° F to +140° F

Finish: PC Board: Protected with moisture/fungus proof varnish.

Chassis: Zinc plated / yellow dichromate.

Terminal Blocks: Industrial screw terminal barrier blocks.

Note 1: Other models available for other frequencies and/or voltages.

Consult factory with your specific requirements.

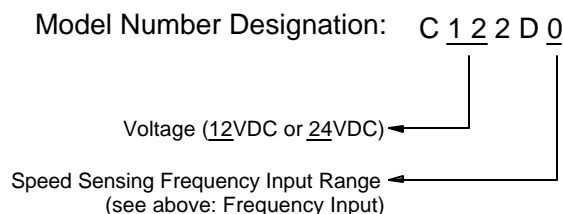

Bouchette Electronics, Inc.

C122D / C242D Dimensions

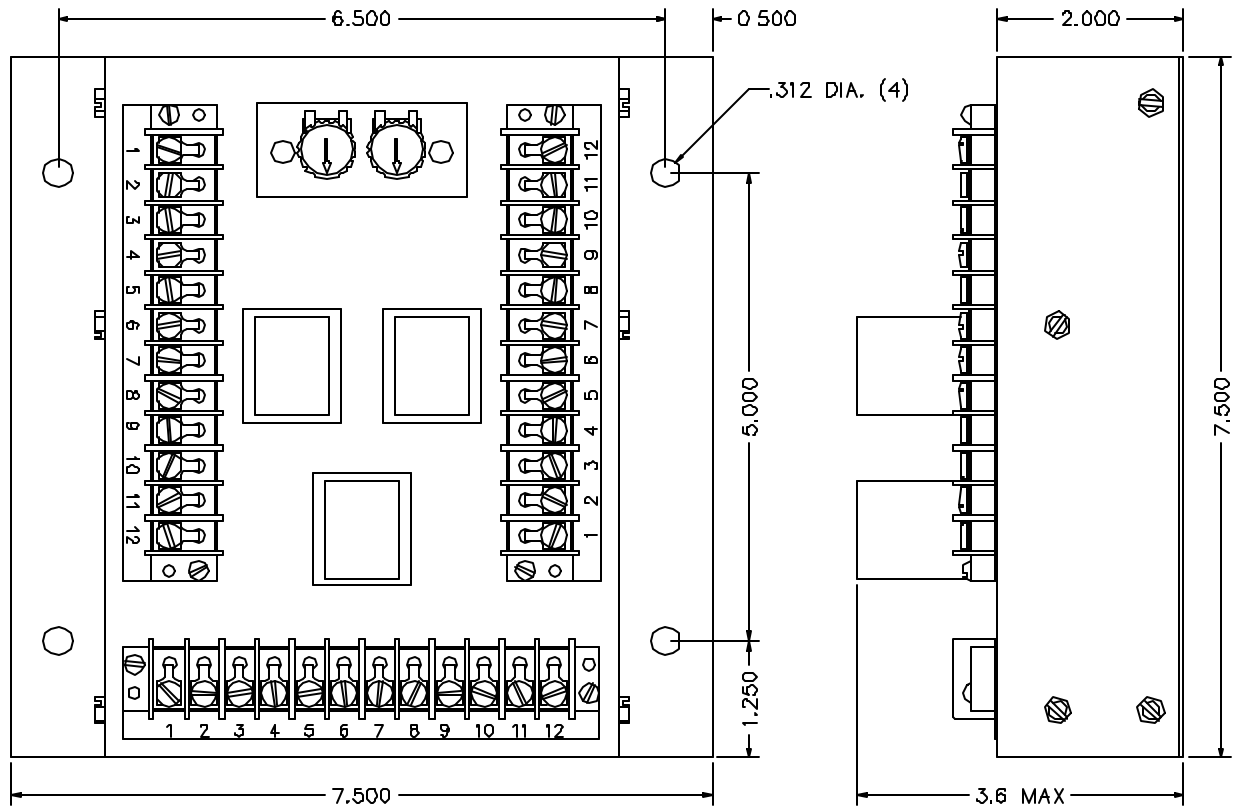

Bouchette Electronics, Inc.

N11325 County Highway Y, Clintonville, WI 54929
(715) 823-7770 (715) 823-7771 Fax www.bouchette.com

GENSET CONTROL MODULE — LEVEL 2

C122D / C242D

Control Switch Inputs

The following operator panel controls are wired into the microprocessor through the front-mounted terminal blocks:

1. Run/Stop/Auto Switch

- a. “Run” position causes the engine to start and run immediately.
- b. “Auto” position allows the unit to be controlled via any remote single-pole dry-type contact (transfer switch, remote start switch, etc.). Contact closure causes the unit to start and run, while contact opening causes the unit to shut down. *Also see Start/Stop Time Delays for time delay options.*
- c. “Stop” position de-energizes the engine control for immediate shutdown.

2. Lamp Test Push-Button

Energizes all alarm lights simultaneously. This feature is disabled with the Run/Stop/Auto selector switch in the “Stop” position, and has no other effect on unit operation. This switch must be in the “Auto” position to test the System Normal Light (SNL).

3. Alarm Silence Push-Button

De-energizes the alarm relay at any time. Any subsequent faults will re-energize the alarm relay.

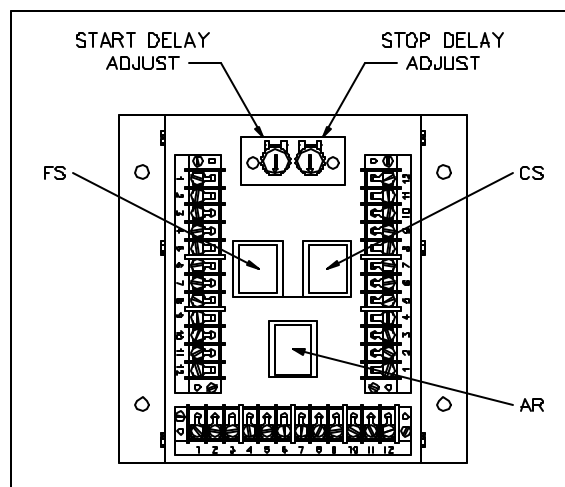

Figure 1 C122D/C242D Genset Control Module

Relay Functions

1. Master Control Relay (FS).

Provides contact (20-amp. maximum) for operation of the fuel solenoid, etc.

2. Cranking Control Relay (CS).

Provides contact (10-amp. maximum) for engine cranking functions.

3. Alarm Relay (AR).

Provides contact (10-amp. maximum) for remote alarm indication, bell, etc. The alarm relay is energized for all engine fault conditions.

Operating Instructions

Safety Inputs

1. Low Oil Pressure (LOP) Shutdown.

Monitoring of oil pressure begins 12-seconds after the unit starts and remains in effect until the unit is shut down (*except as noted in section Microprocessor Program Notes.*) Except as noted, closure of this contact while engine is running results in engine fault shutdown and alarm with light indication. The LOP signal is derived from an oil pressure sensor switch mounted on the engine.

2. High Water Temperature (HWT) Shutdown.

The engine coolant temperature sensor monitoring begins immediately with the start signal. However, if the water temperature is excessive prior to start, (i.e., heat soak after shutdown), the unit is permitted to start and the high temperature condition is permitted to exist for up to 60-seconds after the unit is running before an engine fault shutdown and alarm with light indication occurs. If the high temperature condition is corrected within that time period, the microprocessor circuit reverts to normal monitoring. Except as noted, closure of this contact while engine is running results in engine fault shutdown and alarm with light indication. The HWT signal is derived from a temperature sensor switch mounted on the engine.

3. Spare Shutdown (Optional)

Monitoring of the spare input begins 12-seconds after the unit starts and remains in effect until the unit is shut down. Closure of this contact while running results in engine fault shutdown and alarm with light indication. If used, this input is derived from a sensor switch external to the control module.

4. Overspeed (OS) Shutdown / Adjustment.

Overspeed shutdown protection is provided by a frequency sensing network within the control module. The trip point of the frequency network is screwdriver adjustable via a rheostat accessible thru the top of the engine control as shown. Clockwise rotation increases the trip frequency and thereby, raises the shutdown speed. Exceeding this speed will result in engine fault shutdown and alarm with light indication.

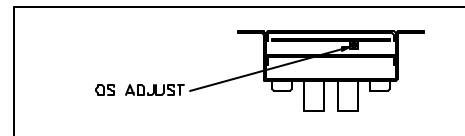

Figure 2. Genset Control Module OS-Adjustment

5. Approach Alarms (Pre-Alarms)

The control module also accepts one additional input for both LOP & HWT. Closure of either of these contacts while engine is running results in alarm with respective light indication, without shutting the unit down. This permits detection of an impending shutdown and is intended to warn that a shutdown may occur. Each alarm light will self-extinguish as its approach fault is corrected. The alarm relay will automatically de-energize if all alarm lights are extinguished. *Also see section Alarm Silence Push-Button.* If used, these inputs are connected to the engine mounted sensor switches similar to those used for the shutdown feature.

Special Outputs

1. Off-Auto Light (OAL)

Provides flashing light indication that Run/Stop/Auto selector switch is not in the “Auto” position and has no other effect on unit operation.

2. System Normal Light (SNL)

Indicates that all conditions are normal. Engine may or may not be running, but is ready to be run via the Remote Run input.

Cranking Control

1. Overcrank (OC) Protection.

Two different cranking cycles are programmed into the control modules microprocessor:

a. Fixed Single Cycle.

Provides a single, non-adjustable, crank period of 48-seconds. Failure of the engine to start within that time results in an “overcrank” fault shutdown and alarm with light indication.

b. Cycle Cranking Feature.

The controller may be field-converted to the “cycle cranking” feature by cutting the jumper wire located through the access hole nearest the middle of the back of the controller as shown. This feature provides a series of five cranking cycles; each containing a 12-second crank period with a 12-second rest period. Failure of the engine to start by the end of the fifth crank period results in an “overcrank” fault shutdown and alarm with light indication.

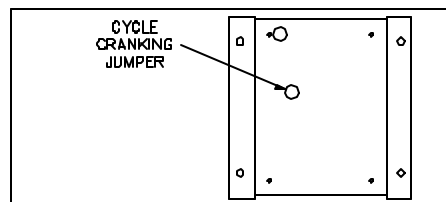

Figure 3 Benset Control Module Backside

2. Cranking Disconnect

The cranking termination speed is obtained from the frequency network within the control module. The microprocessor automatically sets the cranking termination speed at 30% of the selected overspeed trip value.

3. Loss of Frequency Signal

The microprocessor will detect an absence of frequency signal while cranking. After the first 12-seconds of cranking, the “overcrank” light begins a staggered flashing pattern to indicate there is no frequency signal input.

If the optional cycle cranking feature (b) above was selected, the microprocessor overrides this selection and converts to the fixed single cycle cranking feature (a) above, and an “overcrank” engine fault shutdown and alarm with light indication will occur at the end of 48-seconds. *Also see section Microprocessor Program Notes.*

Operating Instructions

Start/Stop Time Delays

The control module provides screwdriver adjustable time delays for starting and/or stopping the unit. The start delay will delay the start-up of the engine for 0-36 seconds after the Remote Run contact is closed. The stop delay will delay the shutdown of the engine for 0-12 minutes after the Remote Run contact is opened. These timing features can be made active only in the “Auto” switch position, and still permits instantaneous manual starting in the “Run” switch position. Placing the selector switch in the “Stop” position provides instantaneous shutdown of the engine under all conditions. The start delay is intended to prevent unnecessary start-ups from momentary remote run signals, and the stop delay is intended to provide a cool-off running period for the engine after load removal. Each timing function has a red light located on the control module face to indicate when in use. Clockwise rotation increases time delay.

Microprocessor Program Notes

Internal protection against loss of frequency input signal is programmed in after the unit has started normally. In the event the frequency goes to zero (engine runs out of fuel, frequency signal source fails, etc.), the LOP shutdown circuit is bypassed and a 12-second wait period is initiated. If the frequency returns within this time period, LOP monitoring resumes and operation continues normally. If frequency has not returned at the end of this time period, the engine oil pressure status is observed to determine whether the engine is actually running or stopped. If the engine has stopped, the cranking cycle will begin in an effort to restart the engine. If the engine has not stopped (loss of input signal, etc.), the unit will display an “overcrank” indication and alarm, and will continue to run **WITHOUT OVERSPEED PROTECTION** until stopped in a normal manner. Re-starting at a later time is prevented until the overcrank indication has been reset.

Warning: “Overcrank” indication can mean a loss of frequency input signal during the previous run period. Attempting to restart the engine without any frequency input signal can destroy the starter motor, which can cause serious personal injury. The frequency signal source is a key component in this system and must be checked out thoroughly whenever an “overcrank” shutdown occurs, since the control module only provides an indication of loss of signal during startup.

Resetting A Fault Shutdown

A shutdown with alarm, due to any fault condition, will prevent any subsequent operation of the generator set. The Run/Stop/Auto selector switch on the operator control panel must be momentarily placed in the “Stop” position to reset these functions.

Bouchette Electronics, Inc.

N11325 County Highway Y, Clintonville, WI 54929
(715) 823-7770 (715) 823-7771 Fax www.bouchette.com

GENSET CONTROL MODULE—LEVEL 1 & 2

Overspeed Selection Formula

The Genset manufacturer must determine the overspeed (OS) trip point based on maximum allowable speeds for both the engine and generator.

The following formula should be used to determine the OS trip frequency for any engine¹. Select a Genset Control model which OS frequency range includes the desired trip frequency.

- 1) All engines with magnetic pick-up sensing (*recommended*):

$$\text{OS Frequency} = 30 \times D \times (\text{number of teeth on ring gear})$$

- 2) All engines with belt-driven alternator sensing:

$$\text{OS Frequency} = 15 \times D \times (\text{number of alt. poles}) \times \frac{(\text{drive pulley diameter})}{(\text{alt. pulley diameter})}$$

- 3) All engines with flywheel-type alternator sensing:

$$\text{OS Frequency} = 15 \times D \times (\text{number of alternator poles})$$

- 4) Gasoline engines only, with distributor ignition sensing:

$$\text{OS Frequency} = 15 \times D \times \text{number of cylinders}$$

D = Speed Multiplier

i.e. If OS is set at @ 72Hz (on 60Hz generator),
then D = 1.2 (1.2 × 60Hz = 72Hz)

¹These formulae are for nominal 1800 RPM engines; for 3600 RPM engines, the calculated OS frequency should be doubled.

Bouchette Electronics, Inc.

Important Notice

OVERSPEED MODEL SELECTION—C121 / C122

<u>Available Models</u>	<u>Typical Frequency Input Sources</u>	At engine overspeed, the Input Frequency is between:
C121x6 C241x6 C122x6 C242x6	Generator frequency (with step-down XFMR) Distributor ignition sensing (low-voltage terminal)	31 - 90 Hz
C121x9 C241x9 C122x9 C242x9	Distributor ignition sensing (low-voltage terminal) Flywheel alternator sensing	82 - 250 Hz
C121x8 C241x8 C122x8 C242x8	Flywheel alternator sensing	150 - 325 Hz
C121x0 C241x0 C122x0 C242x0	Belt-driven alternator sensing	235 - 690 Hz
C121x3 C241x3 C122x3 C242x3	Belt-driven alternator sensing (extended)	550 - 1100 Hz
C121x2 C241x2 C122x2 C242x2	Magnetic pick-up sensing	1750 - 5000 Hz
C121x1 C241x1 C122x1 C242x1	Magnetic pick-up sensing (extended)	2380 - 6800 Hz

Bouchette Electronics, Inc.

N11325 County Highway Y, Clintonville, WI 54929
(715) 823-7770 (715) 823-7771 Fax www.bouchette.com

GENSET CONTROL MODULE

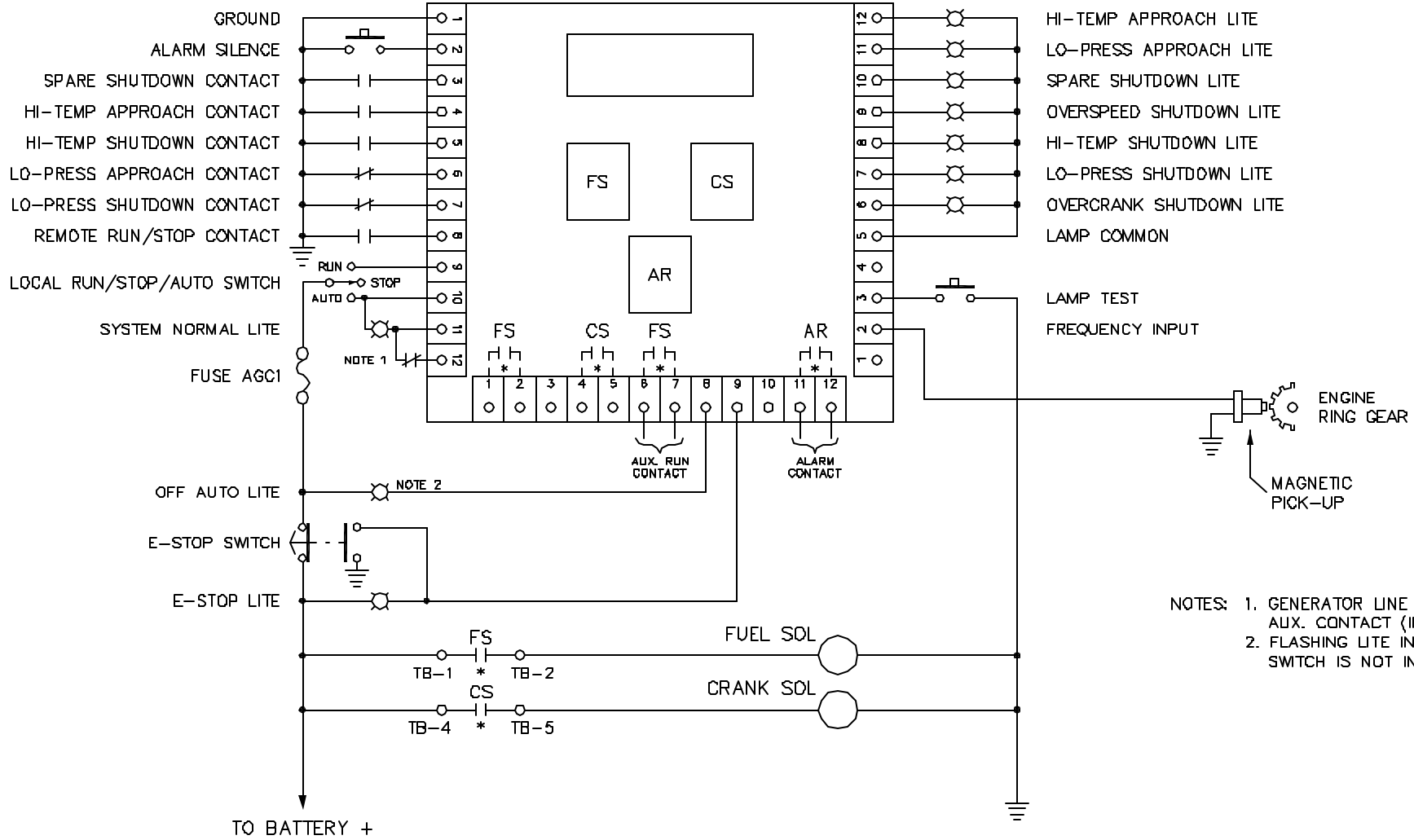

- NOTES: 1. GENERATOR LINE CIRCUIT BREAKER AUX. CONTACT (IF USED.)
 2. FLASHING LITE INDICATES WHEN SWITCH IS NOT IN AUTO POSITION.

* RELAYS AR,FS,&CS ARE INSIDE THE GENSET CONTROL.

FREQUENCY SENSING FROM MAGNETIC PICK-UP

Bouchette Electronics, Inc. N11325 County Highway Y Clintonville, WI 54929			
TITLE CONNECTION DIAGRAM C122D2/C242D2 CONTROL			
DATE 04-05-95	DWN BY DSB	CHK TJB	SCALE NONE
P/N	CAD REF PCB120	DWG NO E171-2	